



## **Edith Cowan University**

2022 ATAR Revision Seminar

### **ATAR Physics**

Curriculum Dot points

Examination and study tips

Revision notes Examination questions

Examination marker comments

Prepared and presented by

**Darin Carter**

# ATAR PHYSICS - REVISION SEMINAR 2022

## Topic 1. GRAVITY

$$F_g = \frac{GM_1m_2}{r^2} \quad g = \frac{F_g}{m} = G \frac{M}{r^2}$$

- Newton described gravity as a force of \_\_\_\_\_ between objects with \_\_\_\_\_.
- The force is **proportional** to the product of the two masses and \_\_\_\_\_ **proportional** to the \_\_\_\_\_ of the distance between them.
- A **gravitational field** is a region in which a mass experiences a force.
- Its strength is given in \_\_\_\_\_ (Newton's per kg) or as an acceleration in \_\_\_\_\_.
- Gravity decreases with radius according to the inverse square law.
- $2r =$  \_\_\_\_\_ gravity;  $3r =$  \_\_\_\_\_,  $4r =$  \_\_\_\_\_ etc ...

### Example 1

The international space station orbits the Earth with an altitude of about  $3.80 \times 10^3$  km and has a mass of  $4.20 \times 10^5$  kg. What is the gravitational field strength and force at this distance?

### Example 2

Mercury has a mass 22.6 times that of Pluto but its radius is only 2.06 times larger. If the gravitational acceleration on the surface of Pluto is  $0.700 \text{ m.s}^{-2}$ , what is it on Mercury?

## Topic 2. Projectile Motion

- Horizontal and vertical motion can be thought of \_\_\_\_\_.
- In the absence of air resistance, the vertical aspect of motion is the only one with \_\_\_\_\_.
- Therefore horizontal motion is considered to be \_\_\_\_\_ velocity.
- The single most important aspect of any projectile calculation is "\_\_\_\_\_ " since it is \_\_\_\_\_ to both aspects of motion.
- Air time is generally calculated using vertical motion first.

$$v_{av} = \frac{s}{t}$$

- Projectile motion calculations can be divided into three main types.

- Horizontal projection –**

Angle of launch =  $0^\circ$ ,  
s is \_\_\_\_\_.

- Angular projection**, landing at same height.

$v_h = v_a \cos \theta$     $v_v = v_a \sin \theta$   
s = 0 m (\_\_\_\_\_ vertical displacement)  
The greatest range is from  $45^\circ$  projection.

- Angular projection**, lands at different height.

$v_h = v_a \cos \theta$     $v_v = v_a \sin \theta$   
s = \_\_\_\_\_ or \_\_\_\_\_.  
s = total vertical \_\_\_\_\_ (up or down)

$$s = ut + \frac{1}{2}at^2$$

### Key aspects of air resistance trajectory:

- Maximum \_\_\_\_\_ is lower and occurs at a lower \_\_\_\_\_.
- Overall \_\_\_\_\_ is lower.
- Trajectory is \_\_\_\_\_ → downward trajectory \_\_\_\_\_.

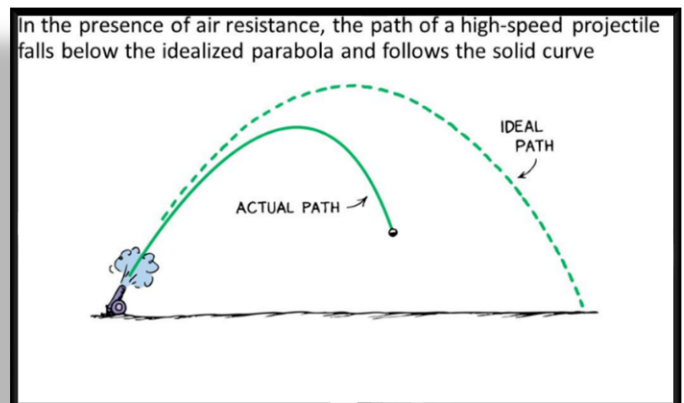

### Example 3 – Unknown Horizontal Displacement

A basketballer, throws a shot into the basket as shown. How far is the basket from the player?

#### Quadratic Method

Convention : UP = +ve

$$s_v = 3.05 - 2.40\text{m} = 0.65\text{ m up}$$

$$v_v = 12 \sin 35^\circ \text{ m.s}^{-1}$$

$$a_v = -9.80 \text{ m.s}^{-2} \text{ (down)}$$

$$v_h = 12 \cos 35^\circ \text{ m.s}^{-1}$$

$$t = ?$$

$$s_h = ?$$

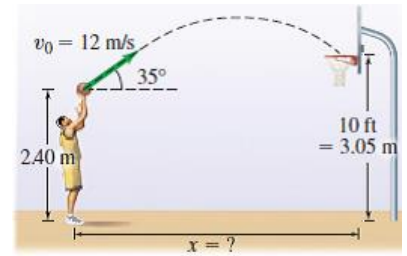

#### Two Step Method

### Example 4 – Unknown INITIAL VELOCITY

A volcanic eruption launches a piece of molten rock 5.00km from the vent as shown. With what velocity was the rock erupted?

Convention : DOWN = +ve

$$s_v = 1250 \text{ m (down)}$$

$$v_v = -v \sin 35^\circ \text{ m.s}^{-1} \text{ (up)} \quad a_v = 9.80 \text{ m.s}^{-2} \text{ (down)}$$

$$v_h = v \cos 35^\circ \text{ m.s}^{-1}$$

$$s_h = 5000 \text{ m?}$$

$$t = ? \quad \text{(Same for all components)}$$

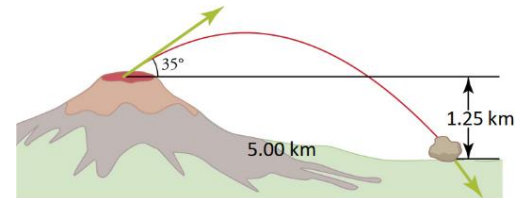

### Topic 3. HORIZONTAL CIRCULAR MOTION

- In circular motion, an object \_\_\_\_\_ towards the centre of the circle.
- This is the \_\_\_\_\_ acceleration -  $a_c$
- The centripetal force  $F_c$  that causes the acceleration must also be towards the \_\_\_\_\_ of the circle
- Centripetal Force is always the \_\_\_\_\_ in circular motion.

#### Example 5 - CHANGE IN VELOCITY and ACCELERATION

If a car is travelling the wrong way around a roundabout as shown. What is the direction of its change in velocity from the moment that it is heading north, to the moment it is heading west? Prove your answer using vectors.

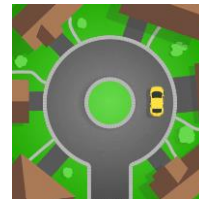

Question 9

**2018 ATAR**

(6 marks)

Cars A and B are moving in a circle around a horizontal dual lane roundabout at a constant speed of  $30 \text{ km h}^{-1}$  as shown in the diagram below. (Note: diagram not to scale.)

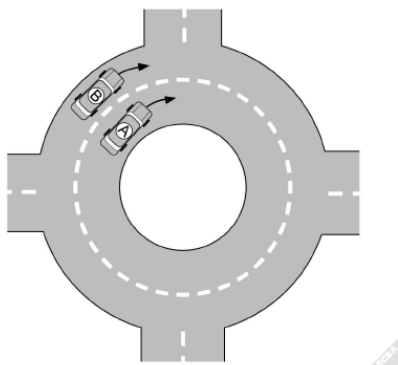

- (a) Compare the acceleration of cars A and B. Include an equation in your answer. (3 marks)

#### EXAMPLE 7 – Gerbils

Two small furry gerbils are taking a ride on an old school turntable spinning at  $33\frac{1}{3}$  rpm. They have identical masses.



If the turntable speed is slowly increased to 78 rpm, which gerbil is most likely to slide off first?

Prove your answer using appropriate equations that show the relationship between the **force** required to hang on and **radius**.

## Topic 4. VERTICAL CIRCULAR MOTION

- ❑ As with all circular motion, the \_\_\_\_\_ is always the Centripetal force.
- ❑ In vertical circular motion, the weight force of can have a component that acts in the \_\_\_\_\_ or \_\_\_\_\_ direction to the required centripetal force.
- ❑ This can mean that the **external force** required to maintain circular motion is either \_\_\_\_\_ or \_\_\_\_\_, depending on position in the circle.
- ❑ Depending on the situation in the problem, the external force may be described as a \_\_\_\_\_ **force**, \_\_\_\_\_, or \_\_\_\_\_ **force**

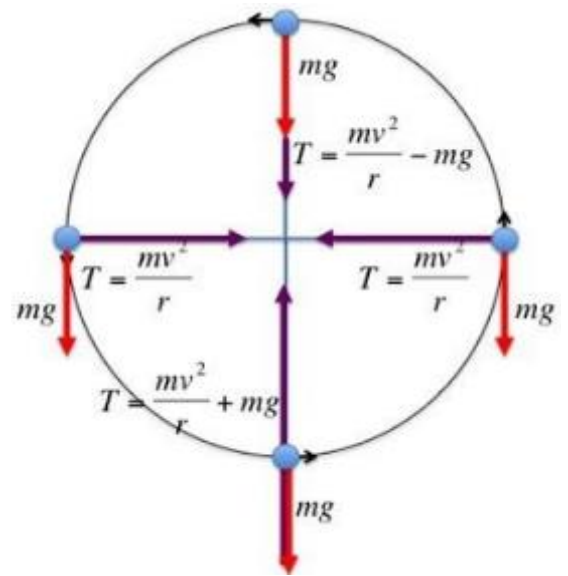

Question 6

**2013 ATAR**

(3 marks)

A car is driving over a hill with a radius of 250 m at a speed of 30.0 m s<sup>-1</sup>. Determine the magnitude of the net force experienced between a 65.0 kg passenger and their seat or seat belt.

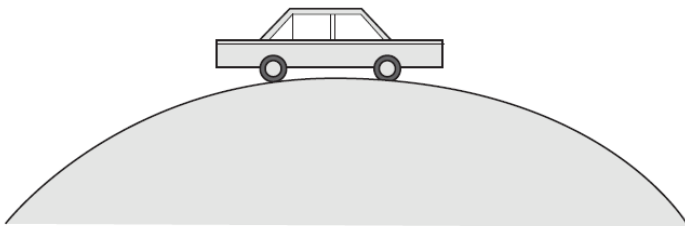

Question 13

**2016 ATAR**

(5 marks)

A 53 kg skater is attempting to complete a loop that is 2.50 m in radius. Estimate the minimum speed at the top of the loop needed for the skater to maintain contact with the top of the loop.

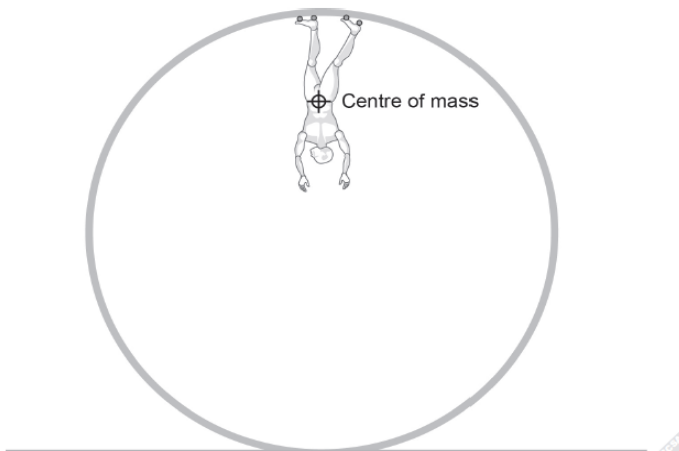

## Pendulums and Non-Uniform Circular Motion

- A pendulum is an example of \_\_\_\_\_ circular motion.
- The mass swings through a circular arc but its \_\_\_\_\_ changes due to \_\_\_\_\_ to \_\_\_\_\_ energy conversions.
- Because the speed is not constant, the required \_\_\_\_\_ force also changes.
- This means that the \_\_\_\_\_ varies as well.
- A roller coaster could also be used as an example of non-uniform circular motion.

### Example 8 - Non-Uniform Circular Motion

Mr Carter's dog "Tess" enjoys playing on the swing when she goes for "walkies" down at the park.

The swing has two 2.50 m long cables, and each is under a maximum tension of 341 N. If Tess swings back and forward from a height of 1.65 m above her lowest position, what is her mass?



## Topic 5. Orbital CIRCULAR MOTION

- Orbital motion, is a form of circular motion that where the centripetal force is provide by gravity.
- In his third law of planetary motion, Kepler stated that "The ratio of *period* \_\_\_\_\_ to *orbital radius* \_\_\_\_\_ will be the same for all objects orbiting the same body". i.e \_\_\_\_\_ is a constant for orbits around the same central \_\_\_\_\_.
- By substituting the formula for circular velocity into Newtons equations, we can demonstrate that Kepler's 3<sup>rd</sup> law holds true with Newton's law of gravitation.

### Deriving Kepler's 3<sup>rd</sup> LAW

- Newton's Law of Universal Gravitation is used to explain Kepler's laws of planetary motion and to describe the motion of planets and other satellites, modelled as uniform circular motion

*This includes deriving and applying the relationship*

$$\frac{T^2}{r^3} = \frac{4\pi^2}{GM}$$

NOTE – ALL geostationary satellites:

1. orbit above the \_\_\_\_\_ in the same direction as the Earth's rotation.
2. have a \_\_\_\_\_ of exactly 24hrs.
3. have the same orbital speed and altitude.

### Example – The International Space Station

The international space station orbits the Earth once every 92 minutes. What is its altitude above the Earth's surface?



### Topic 6. TORQUE and Equilibrium

- Torque or “moment of a force” is the rotational effect of a force which is applied to an object which can pivot.
- Torque is measured in \_\_\_\_\_ (Newton metres)
- Torque is increased when:
  - A greater \_\_\_\_\_ is used.
  - The force is applied at a greater \_\_\_\_\_ from the pivot.
  - The force is closer to \_\_\_\_\_ with the pivot.
- If the force and radius of the lever arm are not perpendicular, the component of the radius which is perpendicular to the line of action of the force is used.
- This is equal to \_\_\_\_\_ where  $\theta$  is the angle between the radius and force.
- Equilibrium in any context is about \_\_\_\_\_.
- In Physics there are a number of different ways we can classify equilibrium.
  - \_\_\_\_\_, \_\_\_\_\_ or \_\_\_\_\_ Equilibrium
  - Translational, \_\_\_\_\_ Rotational or Static Equilibrium

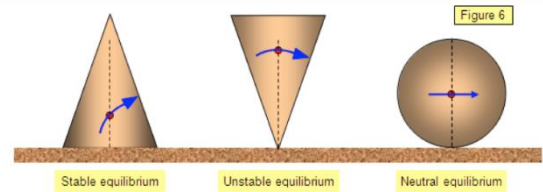
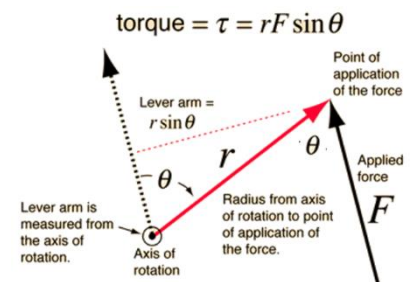

### WRITTEN Example – Equilibrium (Similar to the Bobo Question in 2021 WACE exam)

Weeble's were a range of children's toys released by Hasbro in 1971, but have had a number of “comebacks in recent times”. Tipping a Weeble over to one side caused a weight located at the bottom-centre to be lifted off the ground. Once released, the Weeble quickly rocked back into an upright position. With the aid of a diagram as well as your understanding of equilibrium and moments, explain how a Weeble works.

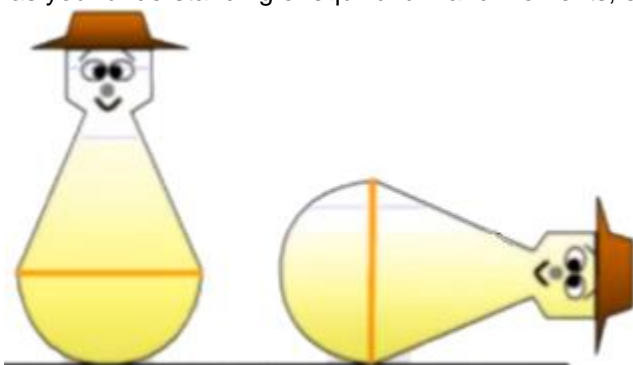

### ANSWER

The Weeble's \_\_\_\_\_ is very low and its bottom is curved. When the Weeble is tipped over on its side, its centre of mass needs to be \_\_\_\_\_, indicating that it is in \_\_\_\_\_ equilibrium. If the force is removed, the \_\_\_\_\_ from the centre of mass falls \_\_\_\_\_ the \_\_\_\_\_.

This causes a \_\_\_\_\_ that returns the Weeble back to its original position.

### Example - Translational Equilibrium

A 2000 N mass hangs by two cords connected as shown. Calculate the tension in each cord.

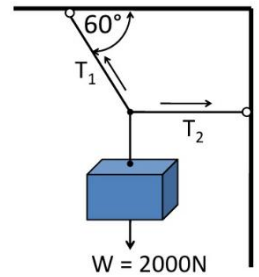

### Example - Static Equilibrium

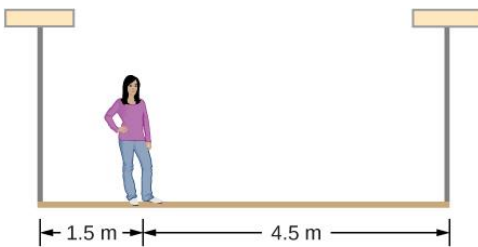

A woman with a mass of 50.0 kg stands 1.50 m away from one end of a uniform 6.00 m long scaffold whilst washing some windows. The scaffold has a mass of 70.0 kg and is suspended from the side of the building by two cables. Find the tensions in the two vertical cables supporting the scaffold.

### FOR EXPERTS - STATIC Equilibrium

A uniform 40.0-kg scaffold of length 6.0 m is supported by two light cables, as shown. An 80.0-kg painter stands 1.0 m from the left end of the scaffold, and his painting equipment is 1.5 m from the right end. If the tension in the left cable is twice that in the right cable, find the tensions in the cables and the mass of the equipment.



### Example - Static Equilibrium

An 80.0 kg bricklayer places a 3.9 m long ladder with a mass of 12.0 kg against a vertical brick wall so that it makes a 60 degree angle with the ground. He then climbs two-thirds of the way up the ladder. What forces are provided by the contact with the wall, **and** with the ground? Assume the brick wall is frictionless.

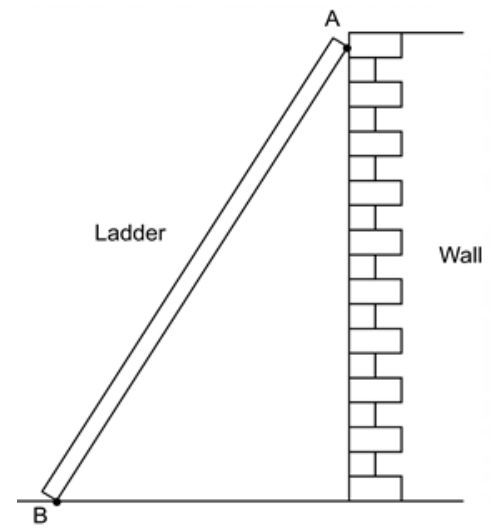

### Example - Static Equilibrium

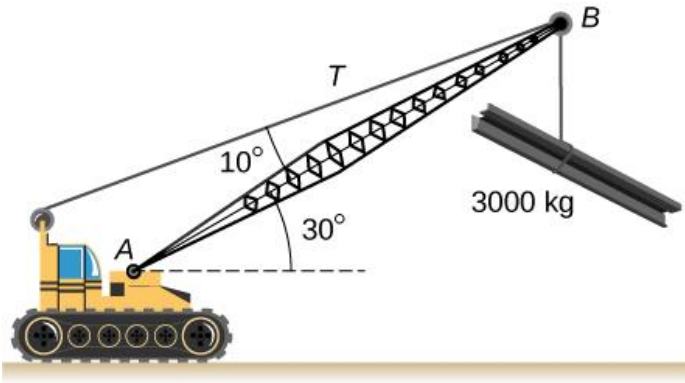

A 12.0-m boom (AB) of a crane lifting a 3000 kg load is shown left. The boom's centre of mass is exactly halfway up its length and it weighs 1000 kg.

For the position shown, calculate tension  $T$  in the cable and the force at the axle A.

Calculate the force at the axle A  $\rightarrow$  using  $\Sigma F = 0$

$$\Sigma F = 0$$

$$a^2 = b^2 + c^2 - 2bc \cos A$$

$$a^2 = 1.71 \times 10^5^2 + 3.92 \times 10^4^2 - 2 \times 1.71 \times 10^5 \times 3.92 \times 10^4 \cos 110$$

$$a^2 = 3.536 \times 10^{10}$$

$$a = 1.88 \times 10^6 \text{ N}$$

$$a = 1.88 \times 10^6 \text{ N @ } 31.3^\circ \text{ up from horizontal}$$

$(4000 \times 9.8)$   
 $c = 3.92 \times 10^4 \text{ N}$

$a = ?$

$110^\circ$

$70^\circ$

$\theta^\circ$

$20^\circ$

$b = 1.71 \times 10^5 \text{ N}$

To calculate angle

$$\frac{1.88 \times 10^6}{\sin 110} = \frac{3.92 \times 10^4}{\sin \theta}$$

$$\theta = 11.29^\circ$$

1. Identify the variables in the data given.
2. Determine the dependent and independent variable.
3. Examine the formulae given or on data sheet) to see how they are related.
4. Rearrange the equation in a  $y = mx + c$  format, so that the \_\_\_\_\_ variable is in the x position and the \_\_\_\_\_ variable is in the y position.
5. If the data needs to be manipulated (e.g. \_\_\_\_\_ or \_\_\_\_\_) to match the equation style, this should be done prior to graphing.
6. Determine the **part of the equation** which is the \_\_\_\_\_. There may or may not be a "+c" in the equation.
7. Draw the graph with the correct variable on each axis.
8. Draw in a "trend line" or "line of best fit".
9. Choose two **DISTANT** points on the line and draw \_\_\_\_\_ lines.
10. Calculate the \_\_\_\_\_ of the line of best fit.
11. Remember to include the units for the gradient. (\_\_\_\_ units / \_\_\_\_ units or \_\_\_\_\_)
12. Apply gradient to equation to calculate unknown,

Andrew and Sarah were at the park and noticed a tyre-swing hanging in a tree. They realised that it would behave as a pendulum and would complete one swing (return to its starting point for one complete cycle) with a period (T) in seconds. They had previously discussed pendulums in class and been given the equation:

$$T = 2\pi \sqrt{\frac{\ell}{g}}$$

[Where  $\ell$  = length in metres]

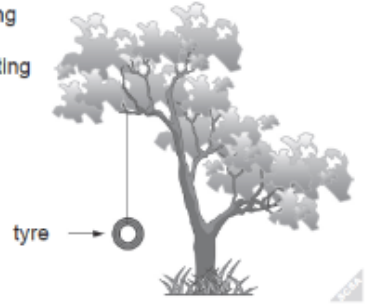

Andrew and Sarah decided to conduct an investigation to determine the relationship between the length of a pendulum and its period.

An incomplete table of results for this investigation is shown below:

Length of pendulum $\ell$ (m)	Time for ten swings (s)	Time for one swing T (s)	
0.10	5.5	0.55	0.30
0.20	6.9	0.69	0.48
0.30	10.9	1.09	1.19
0.40	12.5	1.25	1.56
0.50	15.0	1.50	2.25
0.60	18.5	1.85	3.42

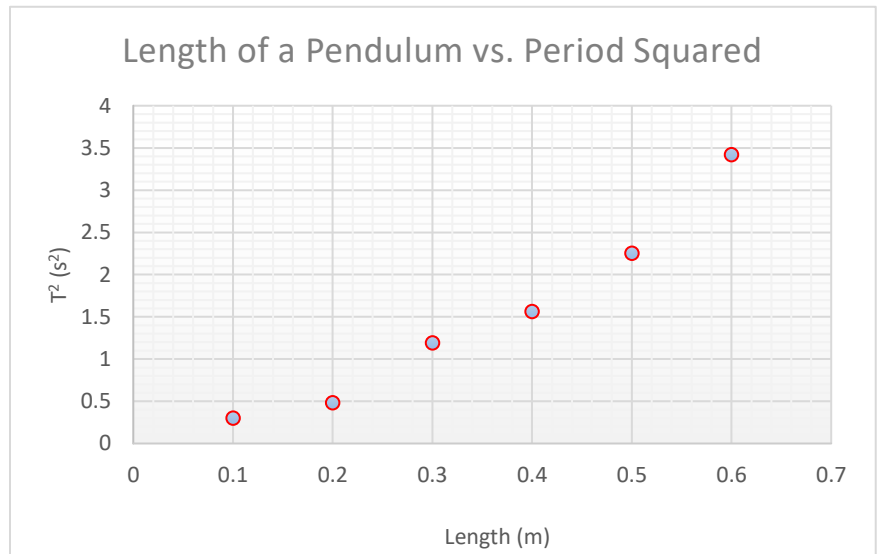

## Topic 8. Forces in Electric and Magnetic Fields

### Coulombs Law

- The force between two charged particles is \_\_\_\_\_ to the product of their charges
- and inversely proportional to the \_\_\_\_\_ between them.
- The constant of proportionality is known as Coulombs constant and is sometimes presented as  $9.0 \times 10^9 \text{ Nm}^2 \text{ C}^{-2}$ .
- Students should **avoid using this value** as it is rounded and our formulae sheet uses  $\epsilon_0$  is called the permittivity of free space
- $\epsilon_0 = 8.85 \times 10^{-12} \text{ F m}^{-1}$  (See constants sheet)

$$F = \frac{1}{4\pi\epsilon_0} \frac{q_1 q_2}{r^2}$$

The value of  $\frac{1}{4\pi\epsilon_0}$  is using  $\epsilon_0$  is a constant for air/vacuum and equal to

### MOVING CHARGE and MAGNETIC FIELDS

Any moving charge results in a **magnetic field**.

- This could be:
  - individual charged \_\_\_\_\_ or
  - \_\_\_\_\_ in a wire
- The magnetic field is \_\_\_\_\_, and \_\_\_\_\_ to the direction of conventional current. (\_\_\_\_\_ charge flow)
- The direction can be predicted using the "right hand \_\_\_\_\_" rule.
- Because it has a magnetic field, a current carrying conductor or moving charge will experience a \_\_\_\_\_ when it interacts with other magnetic fields.
- The direction can of force be predicted using the "Right Hand" Rule.

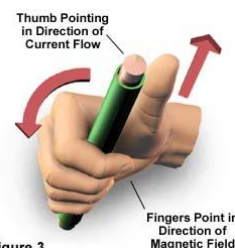

Figure 3

Fingers Point in Direction of Magnetic Field



### Field around a Single Current carrying wire

Point A is 5 cm **to the left** the wire as you look straight down at it. The wire carries 0.325 A of current. What is the field strength and direction at A? Ignore any fields produced by the other wires.

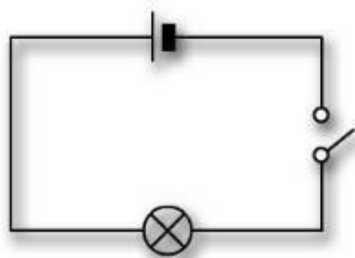

The magnetic field at point P is **zero**. What are the magnitude and direction of the current in the lower wire?

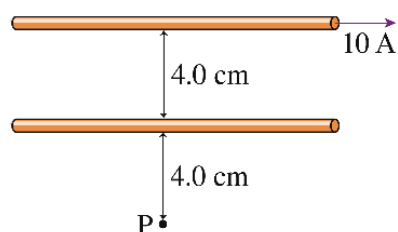

- A. 10 A to the right.
- B. 5 A to the right.
- C. 2.5 A to the right.
- D. 10 A to the left.
- E. 5 A to the left.
- F. 2.5 A to the left.

## THE MOTOR EFFECT

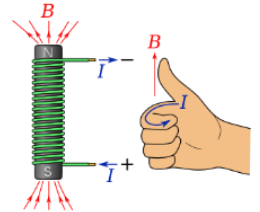
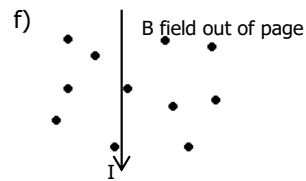
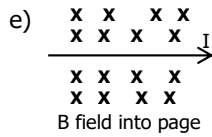
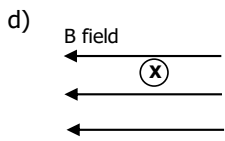
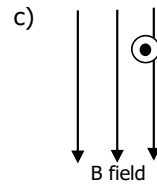
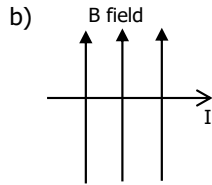
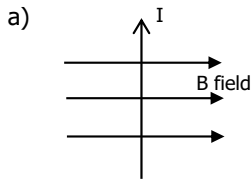

## THE SOLENOID RULE

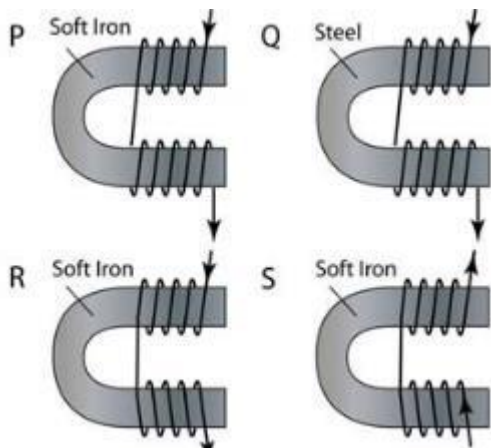
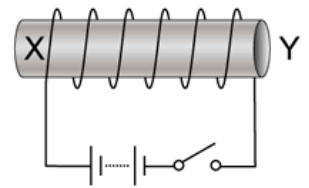
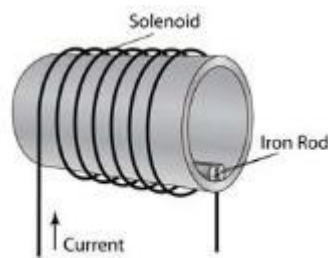
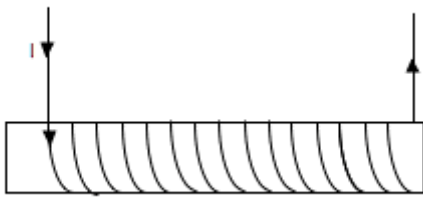

**Question.**  
Which of these four solenoids would have the strongest field between the ends of the metal?

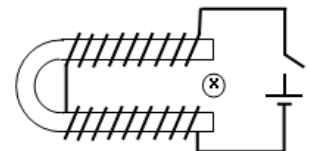
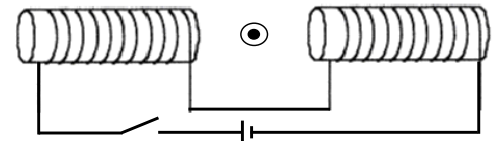

Question 9

# 2015 ATAR

(5 marks)

A physics student sets up an electrical circuit that includes a small toy called a 'slinky', which is essentially a light, coiled metal spring. When the switch is closed and a current is passed through the coil from a small DC battery, the student discovers that a magnetic field exists around the slinky.

- (a) On the diagram below, sketch the shape and direction of the magnetic field that will exist around the slinky when the switch is closed. (4 marks)

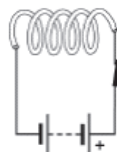

- (b) The student also notices that at the moment that the switch is closed, there is a small movement in the slinky. Describe this movement. (1 mark)

## DC MOTORS

### Function of the Split Ring Commutator

1. \_\_\_\_\_ direction of \_\_\_\_\_ every  $180^\circ$ .
2. \_\_\_\_\_ direction of \_\_\_\_\_ on a specific wire when it reaches the other side.
3. Maintains \_\_\_\_\_ direction of \_\_\_\_\_ / **spin** on motor.

### Motor Calculations

The diagram to the right shows a motor constructed of 25 turns in a  $0.250\text{ T}$  magnetic field. The coils carries  $0.925\text{ A}$  of current.

- a) Label the **direction** of the **current** and **force** on side **YZ**
- b) Calculate the **force** on side **YZ**
- c) Calculate the **torque** produced by the motor.

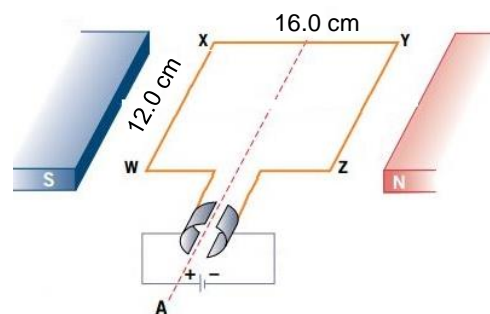

## Forces on Charged Particles

# 2015 ATAR

### Question 10

(4 marks)

An electron travelling at  $1.26 \times 10^7\text{ m s}^{-1}$  entered a uniform magnetic field of intensity  $1.50 \times 10^{-3}\text{ T}$  at right angles to the field lines, as shown in the diagram.

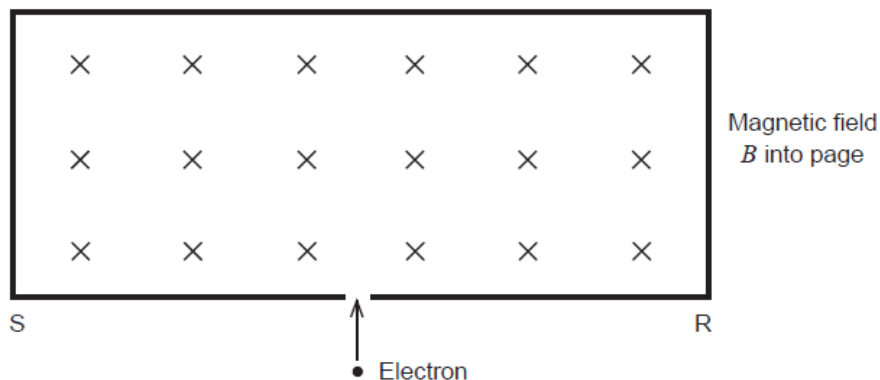

An electron detector located along the line SR recorded an interaction with the electron. Calculate the distance between the entry point and the detector.

## Topic 9. Induced EMF and Current

- An induced emf is produced by the \_\_\_\_\_ **motion** of a straight conductor in a magnetic field when the conductor cuts flux lines.
- Faraday's Law** – The emf induced is proportional to \_\_\_\_\_.

$$\text{induced emf} = \ell v B$$

$$\text{induced emf} = -N \frac{(\Phi_2 - \Phi_1)}{t} = -N \frac{\Delta\Phi}{t} = -N \frac{\Delta(B A_{\perp})}{t}$$

- Lenz's law** – The direction of any **induced** \_\_\_\_\_ will be such that its **own generated** \_\_\_\_\_ **field** opposes the change in \_\_\_\_\_ that created it.

### Example

- An airplane with a wing span of 40m is flying north at  $100\text{ms}^{-1}$  in an area where the Earth's magnetic field is angled downwards at  $35^\circ$  and has an strength of  $15.0 \times 10^{-5} \text{ T}$ .
- What is the emf induced between the wing tips?

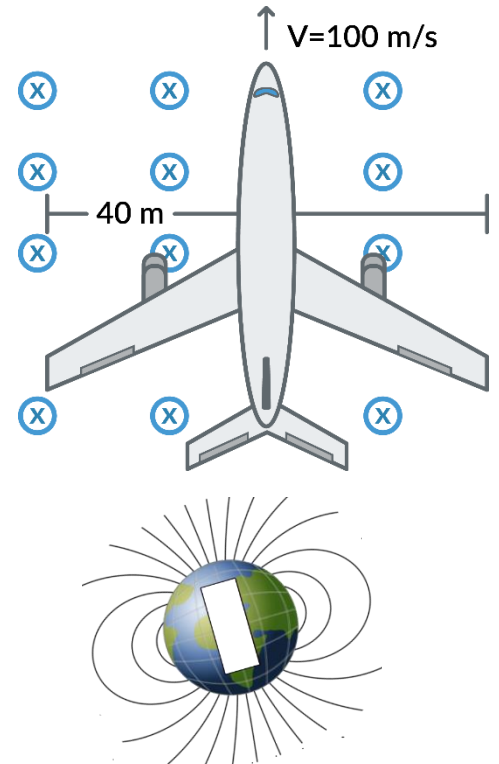

- Which wing tip becomes positive?

- Which hemisphere is the plane in?

# 2017 ATAR

9

PHYSICS

### PHYSICS

#### Question 8

(8 marks)

Complete the table in terms of Motions A, B and C by sketching the emf induced in the loop and state whether the direction of emf is clockwise, anticlockwise or not relevant.

A circular wire loop is placed near a long, straight wire carrying a constant current in the direction shown. The loop moves three times:

- A – it rotates once, uniformly along the X-axis with the resistor R moving out of the page initially
- B – it moves parallel to the straight wire with constant speed
- C – it moves away perpendicularly from the straight wire with constant speed.

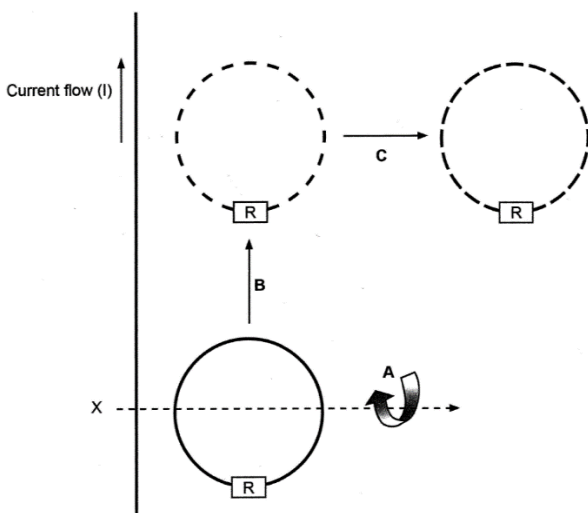

Motion	Possible induced emf in the circular loop with respect to time	The direction of emf (clockwise/anticlockwise/not relevant)
A		
B		
C		

**Generator Problems**

The diagram shows the coil ABCD of an AC generator placed between magnetic poles.

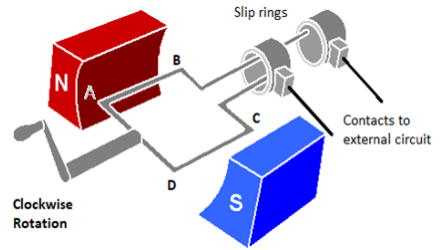

- The uniform magnetic field of flux density 0.204 T is indicated.
- The dimensions of the coil are: AB = DC = 16.0 cm and AD = BC = 10.0 cm
- The coil rotates about the axle as indicated as a torque is applied to the handle.
- The coil has 350 turns of wire and is rotated at 750 rpm.

- b) Calculate the maximum flux contained within the coil ABCD during rotation.
- c) Draw on the diagram the direction of induced current along AB and DC as the coil rotates from the horizontal position shown.
- c) Calculate the magnitude of the maximum emf from the AC generator.
- d) Determine the rms emf produced by this generator.

- e) On the axes provided, sketch the shape of the emf output for this generator as it rotates one full turn from the initial position shown. Add a suitable numerical time scale on the time axis and label your curve '750 rpm'.
- f) Sketch a second shape of the emf output for a rate of rotation of 1500 rpm and label this curve '1500 rpm'.

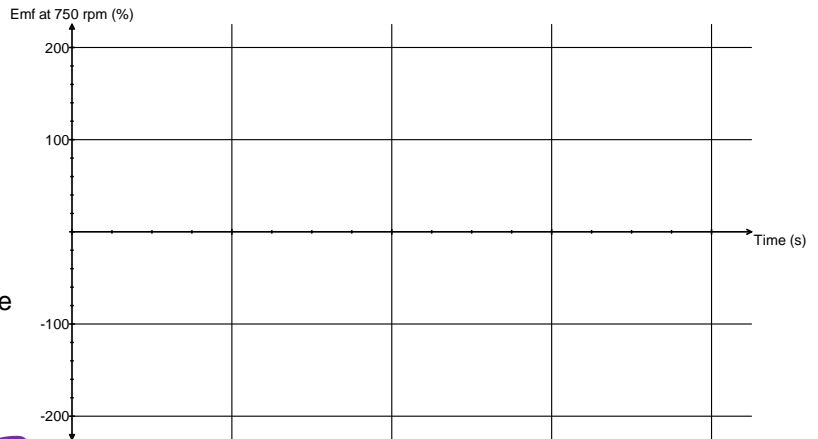

**Transformer Calculations**

**2015 ATAR**

**Question 13**

**(12 marks)**

A mobile phone, of resistance 4.00 Ω was connected to a charger (actually a small step-down transformer). The details of the charger are shown below.

Assume the charger to be 100% efficient.

**PRIMARY COIL**

Input voltage: 240 V AC 50 Hz  
 Turns: 432  
 Power: 6.25 W

**SECONDARY COIL**

Output voltage 5.00 V AC 50 Hz  
 Turns: 9

The 5.00 V AC output of the charger was rectified to 5.00 V DC before charging the battery in the phone.

- (a) State the power output of the secondary coil of the charger. \_\_\_\_\_ W (1 mark)
- (b) Calculate the current flowing through the secondary coil while the battery was charging. Show **all** workings. (2 marks)

- (c) When the mobile phone is charging, 5.00 V DC is used to charge the battery.
- (i) State the number of joules carried by each coulomb of charge. (1 mark)
- (ii) Calculate the amount of energy, in joules, carried by each electron as it charges the battery. Show **all** workings. (3 marks)
- (d) The graph below shows the change in flux experienced by the secondary coil over one complete cycle.

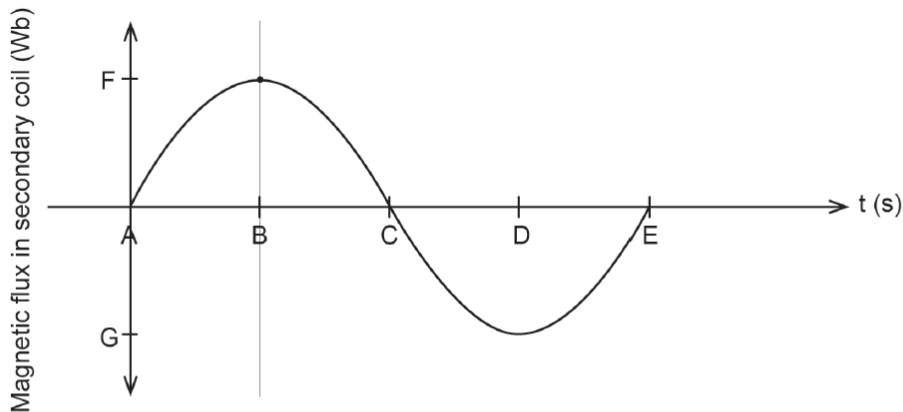

By calculating any required values, and showing **all** workings, determine the magnitudes of the

- (i) time interval AE: \_\_\_\_\_ s. (1 mark)
- (ii) time interval AB: \_\_\_\_\_ s. (1 mark)
- (iii) flux value F at time B: \_\_\_\_\_ Wb. (3 marks)

## Transformer Calculations

# 2013 ATAR

### Question 11

(6 marks)

Inductive charging is becoming more popular for mobile devices such as phones. A simplified diagram of the charging system is shown below.

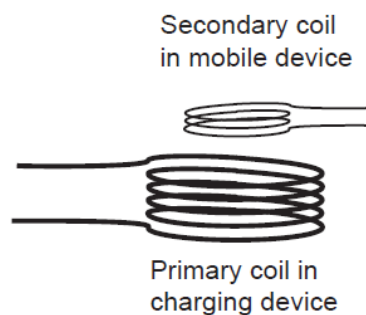

- (a) Assume that one such charging system runs directly from the mains power (240 V AC) to charge a device that requires an input of 4 V. Describe the transformer and the relationship between the two coils. (3 marks)

- (b) Use appropriate formulae or relationships to explain how this inductive charging system works. (3 marks)

### Topic 10. Wave Particle Duality and Quantum Physics

- ❑ EMR is a \_\_\_\_\_ wave with mutually perpendicular, \_\_\_\_\_ and \_\_\_\_\_ fields.
- ❑ Atomic phenomena and the interaction of light with matter indicate that states of matter and energy are \_\_\_\_\_ into \_\_\_\_\_ values
- ❑ EMR has a dual nature, exhibiting both wave and as a particle like properties simultaneously.

Phenomenon	Can be explained in terms of WAVES	Can be explained in terms of PARTICLES
Reflection		
Refraction		
Diffraction		
Interference patterns		
Polarization		
Photo-Electric Effect		

### The Photoelectric EFFECT

- ❑ When EMR is shone onto certain metal surfaces, electrons are excited and ejected creating a “\_\_\_\_\_”
- ❑ If the incoming EMR is too \_\_\_\_\_ in frequency → \_\_\_\_\_ electrons are ejected.
- ❑ Increasing the total energy of the incident EMR by increasing the brightness or intensity, \_\_\_\_\_ change this.
- ❑ If the frequency of incident EMR is \_\_\_\_\_ than the “\_\_\_\_\_ frequency” → photoelectrons will be ejected.
- ❑ Increasing the intensity of the incident EMR increases the \_\_\_\_\_ of electrons released (increased photocurrent).
- ❑ Increasing intensity \_\_\_\_\_ change maximum \_\_\_\_\_ energy.
- ❑ For every metal, there is a certain frequency of light (the threshold frequency), below which no electrons are emitted, no matter how intense the light.
- ❑ Increasing the frequency of incident radiation increases the maximum \_\_\_\_\_ Energy of photoelectrons, but does not change the \_\_\_\_\_ of electrons ejected.
- ❑ We now understand that each photon can only be absorbed by a \_\_\_\_\_ electron.
- ❑ The maximum Kinetic Energy of ejected electrons can be calculated by doing \_\_\_\_\_ on them to reverse their flow.
- ❑ By applying a reverse potential, we create an electric field that reverses the flow of electrons, “stopping” them from leaving the metal surface.
- ❑ This is called the \_\_\_\_\_ potential.
- ❑ Stopping potential is related to the work done on electrons to reduce their kinetic energy to zero.
- ❑ We can then use  $E_{K(max)}$  to calculate work functions for unknown metals.

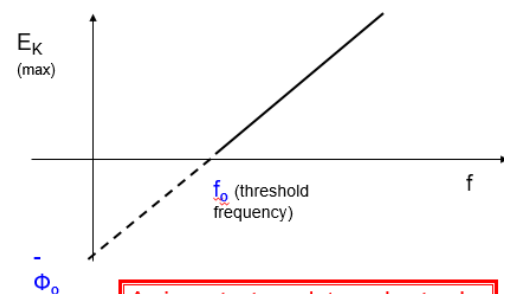
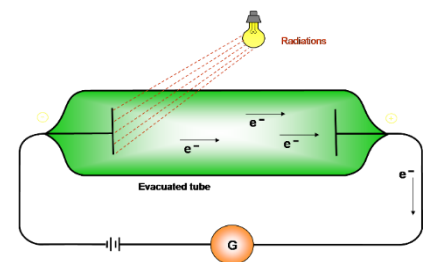

An important graph to understand

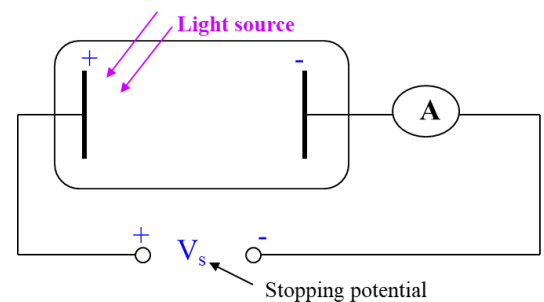

### EXAMPLE - Stopping potential

Light of wavelength 300 nm is incident on a sodium surface, creating a photocurrent. The stopping potential was measured to be 2.29 V. Calculate the work function of sodium. ( $c = 3.0 \times 10^8 \text{ m.s}^{-1}$  and  $h = 6.63 \times 10^{-34} \text{ Js}$ )

## Spectra

- When excited electrons drop down energy levels within an atom, they emit \_\_\_\_\_ with energies (and thus frequencies) corresponding to the energy difference between the two levels. This results in \_\_\_\_\_ spectra.
- Electrons can also absorb \_\_\_\_\_ if the photon \_\_\_\_\_ matches the difference between their energy levels. If white light (a continuous spectrum) is passed through a vapour, only those specific \_\_\_\_\_ will be absorbed leaving an absorption spectra (dark lines).

## Spectra and atomic structure

### 1. Emission spectra

- (i) Line spectra - emitted by hot monatomic gases
- (ii) Band spectra - emitted by gases with more than one atom per molecule
- (iii) Continuous spectra - emitted by hot solids

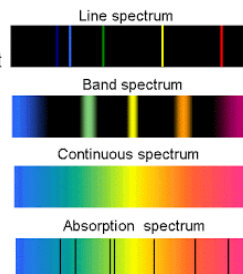

### 2. Absorption spectra

Formed by of light passing through a cooler vapour. The vapour absorbs those regions of the spectrum which it would have emitted had it been in an excited state.

## Question 18

# 2014 ATAR

(13 marks)

A hydrogen atom, in an excited energy level, undergoes relaxation by emitting a photon. The energy values are given by  $E_n = -\frac{13.6}{n^2}$  eV. The initial state of the electron is in energy level  $n = 4$  and the final state after relaxation is in ground state ( $n = 1$ ).

- (a) Does the average radius of the electron orbital remain the same, increase or decrease in value during this transition? Circle the correct answer. (1 mark)

remains the same                      increases                      decreases

- (b) Use the formula  $E_n = -\frac{13.6}{n^2}$  eV to complete the energy level diagram below. The diagram is **not** drawn to scale. (2 marks)

$n=4$  \_\_\_\_\_  $E_4 =$  \_\_\_\_\_ eV  
 $n=3$  \_\_\_\_\_  $E_3 = -1.51$  eV  
 $n=2$  \_\_\_\_\_  $E_2 = -3.40$  eV

Ground state  $n=1$  \_\_\_\_\_  $E_1 =$  \_\_\_\_\_ eV

- (c) On the diagram above, draw in all the possible transitions when an electron undergoes relaxation from  $n = 4$  to the ground state. (3 marks)
- (d) (i) Calculate the wavelength of the photon emitted from the  $E_3$  to  $E_2$  transition. Show all workings. (4 marks)
- (ii) The transitions of  $E_4$  to  $E_2$  and  $E_3$  to  $E_2$  produce red and green photons. Explain which transition produces which colour. (3 marks)

Number of levels <b>above</b> ground state	Number of possible <b>unique</b> transitions
1	
2	
3	
4	
5	

## Question 14

# 2016 ATAR

(12 marks)

An electron microscope creates a coherent beam of electrons which then travels through two narrow slits. The resulting interference pattern is detected on a photographic plate. The speed of the electrons is 1.00% of the speed of light.

- (a) Show that the de Broglie wavelength of the electrons used is  $2.43 \times 10^{-10}$  m. (2 marks)

- (b) Describe what you expect to see on the photographic plate. (2 marks)

- (c) Explain the behaviour of the electrons in this experiment. (2 marks)

The electrons are exhibiting \_\_\_\_\_ behaviour.  
 As they pass through the slits, \_\_\_\_\_ occurs causing them to spread out into two circular waves  
 The two waves have alternating **constructive** and **destructive** \_\_\_\_\_. (Bright lines vs darker areas).

(d) If the experiment were to be repeated using protons, at what speed would a proton need to travel to have the same de Broglie wavelength as the electrons? (2 marks)

(e) Calculate the potential difference required for the electron microscope to accelerate the electrons to 1.00% of the speed of light. (4 marks)

## Topic 11. Special Relativity

### Two Postulates of Special Relativity

- The laws of physics are the \_\_\_\_\_ for all frames of reference moving at a \_\_\_\_\_ velocity with respect to each other. (No test to prove motion)
- The velocity of light in a vacuum  $c$  is constant for all observers, independent of their state of motion

### Motion at relativistic velocities, results in:

- Time \_\_\_\_\_
- Length \_\_\_\_\_
- Momentum and mass \_\_\_\_\_
- Energy \_\_\_\_\_.

$$t = \frac{t_0}{\sqrt{1 - \frac{v^2}{c^2}}} \quad l = l_0 \sqrt{1 - \frac{v^2}{c^2}}$$

(As observed from an external reference frame).



$$p_v = \frac{m_0 v}{\sqrt{1 - \frac{v^2}{c^2}}}$$

$$E_t = \frac{m_0 c^2}{\sqrt{1 - \frac{v^2}{c^2}}}$$

$$E_k = \frac{m_0 c^2}{\sqrt{1 - \frac{v^2}{c^2}}} - m_0 c^2$$

$$u' = \frac{u - v}{1 - \frac{v u}{c^2}}$$

$$u = \frac{v + u'}{1 + \frac{v u'}{c^2}}$$

## Time Dilation

### Question 12

# 2015 ATAR

(6 marks)

Muons are created in the upper atmosphere with speeds of  $0.990c$  or more. Their average lifetime is  $2.20 \mu\text{s}$  measured at low speeds in the laboratory. A simple calculation shows that most should only travel about 660 m before decaying. Thus, very few muons should ever reach sea level.

- (a) Using relativistic mechanics, calculate how far a muon can travel according to an observer on Earth. (4 marks)

## Simultaneity

There are two pulse lights at each end of car in a train moving with relativistic velocity.

Observer B (outside the train) sees the two pulses at the exact moment that observer A is in line with him.

He notes that the two ends of the car are an equal distance from him at the time of the pulses which reach him at the same time. Thus he concludes that they must have been simultaneous.

**What does observer A see?**

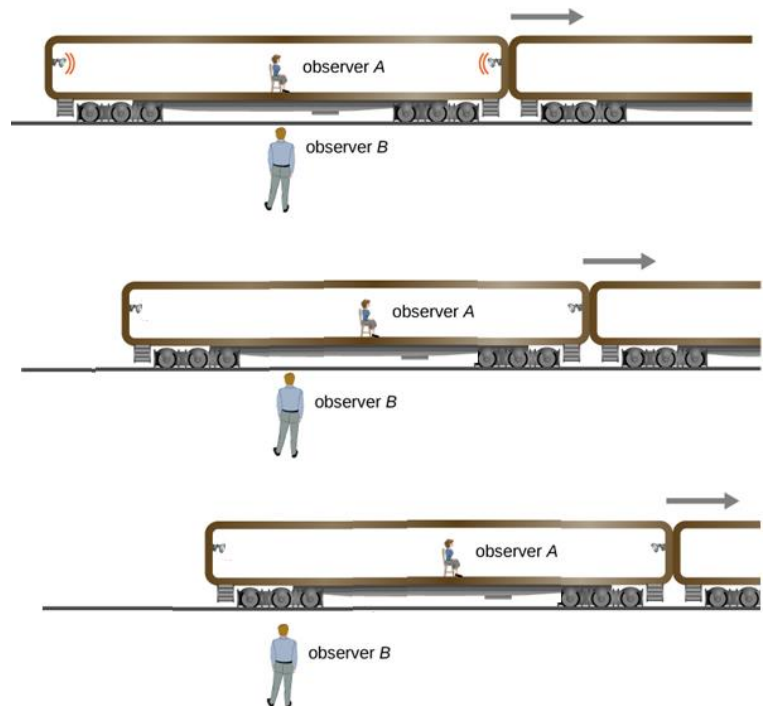

## Length Contraction

Doc Brown has just built a barn, in which he plans to hide his time travelling DeLorean. Marty looks at the barn and tells Doc that there is no way 3.50 m long DeLorean, will fit in the 1.50 m long barn.

The Doc tells Marty .., "It's perfect! You just need to think 4<sup>th</sup> dimensionally about it. If the DeLorean goes fast enough..... It WILL fit!"

Calculate how fast the DeLorean needs to go.

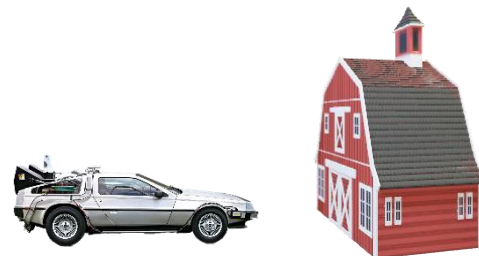

Marty wants to test out your calculation, so he hops in the DeLorean and accelerates to  $0.904c$  before driving through the barn. Marty tells Doc that your calculations were wrong. The DeLorean had more than 1.4 m of its length hanging out **each end** of the barn.

Who is right? Explain your answer. →

## Relative Velocities

# 2015 ATAR

### Question 7

(4 marks)

Two spaceships, 'Albert' and 'Max' are travelling toward each other. Each has a speed of  $0.750c$  as measured in the Earth's reference frame.

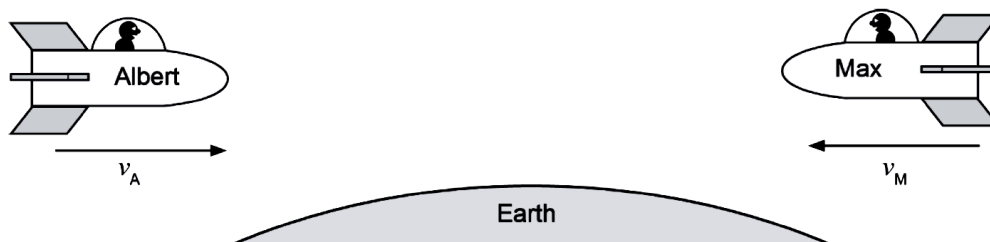

Calculate the velocity of Max as measured by the crew on spaceship Albert.

## Topic 12. The Standard Model and the Big Bang

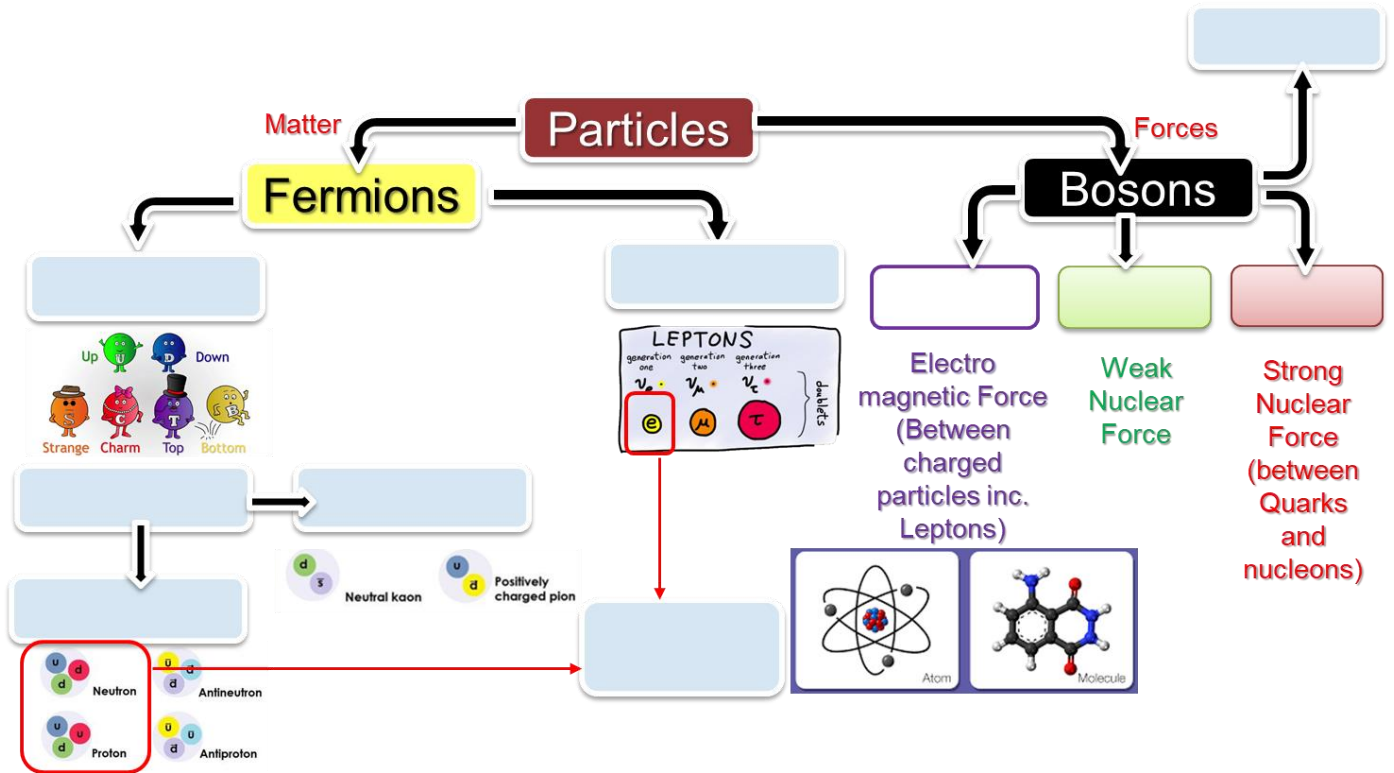

### Models of the Universe

#### Steady State Theory

- Universe always the same \_\_\_\_\_.
- Infinite and expanding with \_\_\_\_\_ continually created to maintain constant density

#### Big Bang Theory

- Universe expanded from a single tiny point 13.7 billion years ago.
- The event caused the creation of space/time and matter.
- It is actually space that is expanding – not matter.

#### Evidence For the Big Bang

- \_\_\_\_\_ – Demonstrated that all galaxies are getting further away from us. The universe is expanding from a highly dense starting point.
- \_\_\_\_\_. Calculations suggest that energy created at the beginning of the universe with the Big Bang, that has been travelling through space ever since would be in the \_\_\_\_\_ range (very short \_\_\_\_\_). The radiation we detect in every direction is a much longer wavelength, in microwave range. Suggests that the waves themselves expanded with the universe. Measured CBR wavelength match predictions based on how much the universe has expanded.
- Abundance of Hydrogen and Helium is greater than would be expected in steady state.

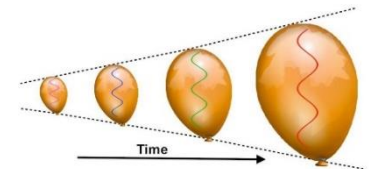
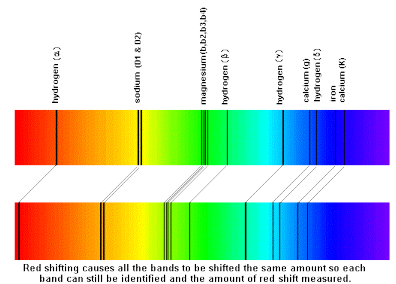

Question 4

(5 marks)

Sirius appears as the brightest star in the night sky. It is actually a binary star consisting of Sirius A, a large blue-white star, and Sirius B, a white dwarf. Our view of the Sirius star system is such that there are times when Sirius B is coming toward us and times when it is going away from us. When Sirius B is moving toward us:

(a) Sirius A will be (1 mark)

- A moving toward us, relative to Sirius B.  
B moving away from us, relative to Sirius B.

(b) Compared to the speed of light approaching us from Sirius A, the speed of the light approaching us from Sirius B will be (1 mark)

- A the same.  
B less.  
C greater.

(c) An astronomer views a spectrum of the visible light from Sirius B. Describe **one** feature of this spectrum that would indicate Sirius B is moving toward the astronomer. (2 marks)

(d) Big Bang theory predicts the Sirius system should be (1 mark)

- A moving toward us.  
B moving away from us.  
C keeping a constant distance.

## Hubble's Law

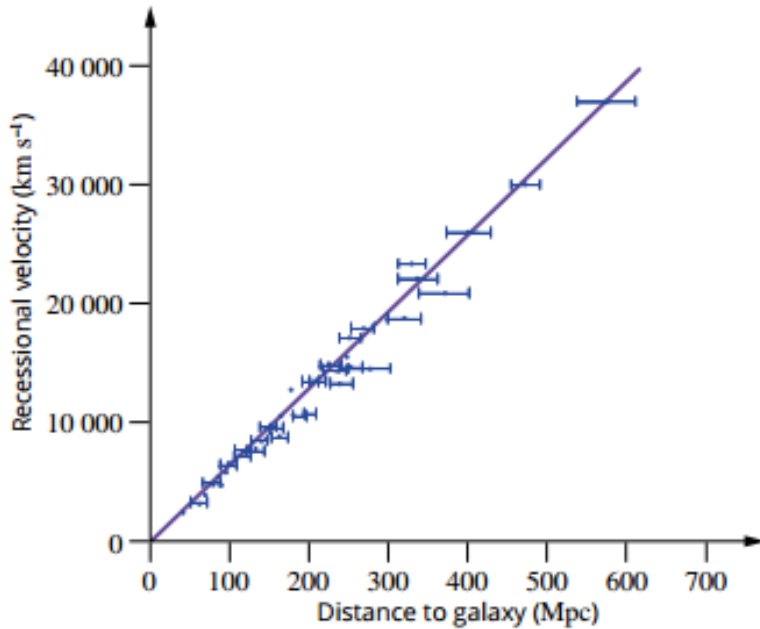

- Hubble noticed that spectra from distant galaxies were \_\_\_\_\_-shifted whichever way he observed the universe.
- They were moving \_\_\_\_\_ from us. (relative motion)
- More distant galaxies were redshifted more than closer ones, indicating higher \_\_\_\_\_.
- Hubble's law states that the distance to a galaxy is directly proportional to its recessional velocity.
  
- $H_0$  is Hubble's constant, which is roughly \_\_\_\_\_

\*\*From data sheet

$$1 \text{ Mpc} = 3.09 \times 10^{19} \text{ km} = 3.26 \times 10^6 \text{ ly}$$

**Example –** Use Hubble's constant to determine the age of the Universe

- The time a galaxy has taken to reach its current distance is related to its recessional velocity and distance travelled.
- Hubble's Law tells us that
- The age of the universe is therefore.

## The Big Bang and the Standard Model of Matter

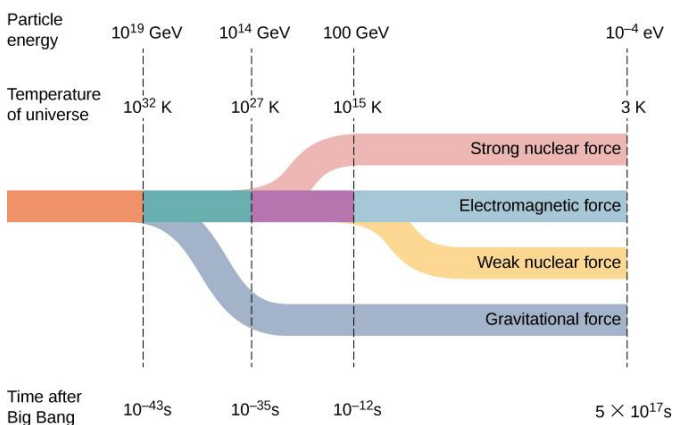

- Before the short period of cosmic inflation, physicists believe that all matter in the universe was squeezed into a space much smaller than an atom.
- The whole universe was in a hot dense state. ☺
- Interactions between particles were governed by a single \_\_\_\_\_ force.
- The unity broke down as the energy decreased, matter formed and the four fundamental forces diverged as shown

## Big bang

- \_\_\_\_\_ and \_\_\_\_\_ form with Gluons and Photons
- \_\_\_\_\_ form (protons, neutrons and mesons)
- Nucleosynthesis - \_\_\_\_\_ and \_\_\_\_\_ form
- \_\_\_\_\_ condenses H and He nuclei into the first stars.
- \_\_\_\_\_ creates \_\_\_\_\_ elements.
- Early stars go \_\_\_\_\_ spreading heavier elements out into universe.
- Gravity continues to cause H and He to form new stars, but heavier elements formed in earlier stars are also condensed to form planetary systems.

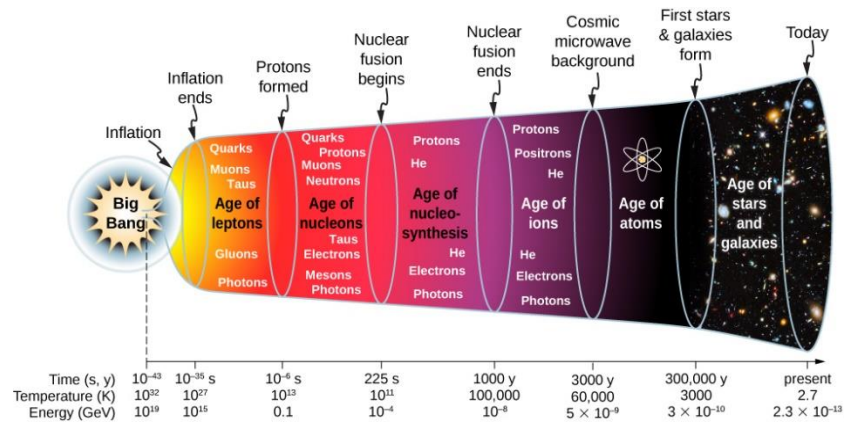

## Standard Model of Matter – Conservation Rules

Particle interactions, such as **decays** and **collisions** obey a number of conservation rules. Conservation of the following quantities should be observed or used to support or invalidate proposed reactions.

- **Baryon Number** (of Baryons and quarks)
- **Lepton Number** (within each family e.g. Electrons, muons and Tau particles)
- **Charge**

Particle	Symbol/s	Baryon Number	Lepton Numbers		
			$L_e$ (electrons)	$L_\mu$ (muons)	$L_\tau$ (taus)
Proton or Neutron	$p / n$				
Anti-proton or anti-neutron	$\bar{p} / \bar{n}$				
Electron or electron neutrino	$e^-$ or $\nu_e$				
Positron or antielectron neutrino	$e^+$ or $\bar{\nu}_e$				
Muon or muon neutrino	$\mu^-$ or $\nu_\mu$				
Anti-muon or anti muon neutrino	$\mu^+$ or $\bar{\nu}_\mu$				
Tau or tau neutrino	$\tau^-$ or $\nu_\tau$				
Anti-tau	$\tau^+$ or $\bar{\nu}_\tau$				
Quarks	$u d t b c s$				
Antiquarks	$\bar{u} \bar{d} \bar{t} \bar{b} \bar{c} \bar{s}$				

Which of the following decays cannot occur because conservation laws are violated? Show all conservation laws.

$$n \rightarrow p + e^-$$

charge

$B$

$L_e$

$$\mu^+ \rightarrow e^+ + \nu_e$$

charge

$B$

$L_e$

$L_\mu$

$$\text{Meson} \rightarrow \pi^+ \rightarrow e^+ + \nu_e + \bar{\nu}_\mu$$

charge

$B$

$L_e$

$L_\mu$

Lambda (quark composition **uds**)

$$p \rightarrow n + e^+ + \nu_e$$

charge

$B$

$L_e$

$$\Lambda^0 \rightarrow \pi^- + p$$

charge

$B$

$L_e$

$$\pi^- \rightarrow e^- + \bar{\nu}_e + \nu_\mu$$

charge

$B$

$L_e$

$L_\mu$



Banked Turns? (sort of)

2015 ATAR

Question 16

(13 marks)

Somnang is an engineer and designed a road that had a horizontal curved section of radius  $(50 \pm 5)$  m. After construction, it was necessary to check that the curvature of the road was constructed within tolerance.

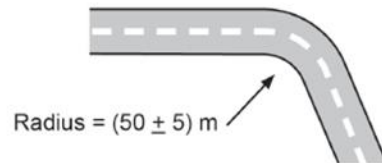

To test the curvature of the road, Somnang hung a small mass of  $1.00 \times 10^2$  g from the rear-view mirror of his car using a light string. He then travelled at a constant speed of  $35.0 \text{ km h}^{-1}$  around the curve. Somnang observed that the string holding the mass settled at an angle of  $10.0^\circ$  to the vertical.

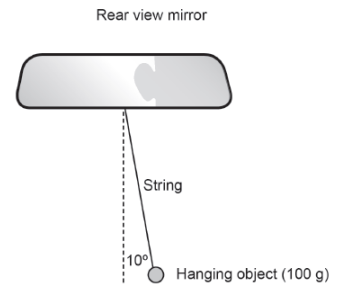

- (a) On the diagram above, draw and label the forces acting on the hanging object. (2 marks)
- (b) Calculate the tension in the light string. Show **all** workings. (3 marks)
- (c) Calculate the centripetal force experienced by the hanging mass. Show **all** workings. (3 marks)
- (d) From the information supplied and your previous answers, determine whether the curvature of the road was correct. Show **all** workings. (5 marks)

Example - Static Equilibrium

A person holds an 80 N weight in their hand, at the end of their arm which has a weight of 20N arm as shown. What force does the bicep muscle need to apply to hold the mass?

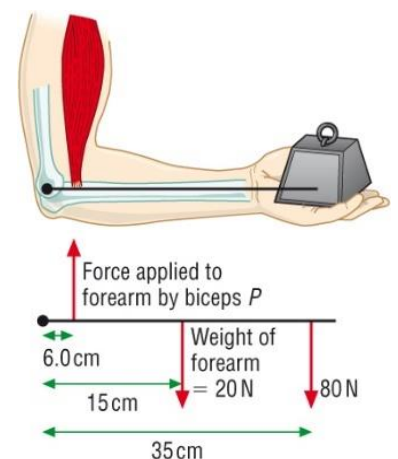

Congratulations! You have now completed your revision booklet!

Edith Cowan University would like to wish all students the best of luck with their future exams!

